

A1067507
IC 40

Amana®

Ice Maker for Side-By-Side Refrigerators

Installation and Operating Instructions

Introduction

This kit contains the component parts of the Automatic Ice Maker. The refrigerator/freezer models for which the kit is designed have a label on the back of the cabinet which identifies them as being suited to the Automatic Ice Maker.

It is strongly recommended that this entire instruction manual be read and thoroughly understood, before actually beginning kit installation. Make sure that you have the necessary tools and other materials for the job. Study the illustrations to become familiar with your appliance and with important details of the installation procedure.

CONSUMER INFORMATION LINE

 **AMANA TOLL FREE**
1-800-843-0304

NOTE

1. Some mechanical experience is required in order to install the ice maker.
2. Installation can take from three (3) to six (6) hours, depending upon the installer's knowledge and skill.
3. If a problem is encountered during installation that the installer is unable to solve, contact your authorized Amana Servicer for assistance. This contact will be at the owner's expense.

IMPORTANT: It is important, both for your personal safety and to avoid possible damage to your appliance or your home, that you observe the safety instructions that are given in a following topic.



**RECOGNIZE THIS SYMBOL
AS A SAFETY PRECAUTION**

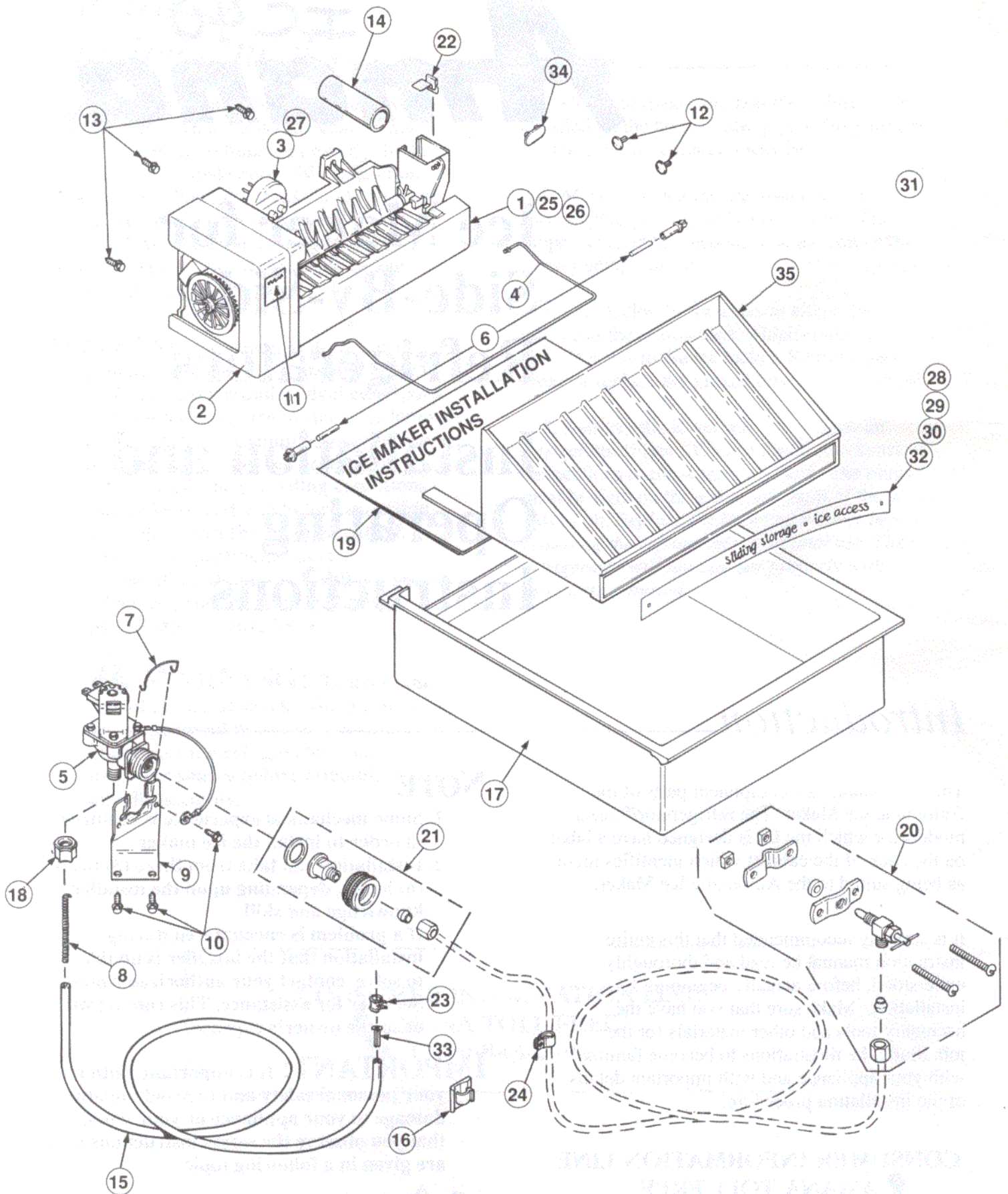

NOTE: Only use supplied parts

ICE MAKER PARTS LIST MODEL IC40

PARTS LIST IS ONLY FOR ORDERING PARTS. PART
NUMBERS ARE NOT USED IN INSTALLATION INSTRUCTIONS.

ITEM	DESCRIPTION	PART NUMBER	QUANTITY
1	ICE MAKER	D7824701	1
2	ICE MAKER COVER (ATTACHED TO ICE MAKER)	D7320401	1
3	WIRE HARNESS (ATTACHED TO ICE MAKER)	D7826301	1
4	SHUT-OFF ARM (ATTACHED TO ICE MAKER)	D7875201	1
5	WATER VALVE	D7712603	1
6	STOP PINS (2 FOR ICE PAN AND 2 FOR JUICE RACK IF NECESSARY)	M0560005	4
7	WATER VALVE CLIP	B8374701	1
8	ANTI-KINK SPRING	A1055101	1
9	BRACKET (FOR WATER VALVE)	D7701601	1
10	3/8" LONG THREAD CUTTING SCREW (BRACKET TO BASE PAN & GROUND SCREW)	M0251015	3
11	WARNING LABEL (ATTACHED TO ICE MAKER COVER)	A3036901	1
12	BUTTON PLUG (LINER SIDE)	M0311301	2
13	5/8" LONG SHEET METAL SCREW (ICE MAKER TO LINER)	M0211018	3
14	FILL TUBE EXTENSION	A3127412	1
15	1/4" PLASTIC TUBE	B5705321	1
16	CLAMP	M0104101	1
17	ICE PAN	D7806201	1
18	NYLON NUT & SLEEVE	M0753001	1
19	ICE MAKER INSTALLATION INSTRUCTIONS	A1067507	1
20	SADDLE VALVE	A3034801	1
21	WATER VALVE COUPLING CONSISTING OF PARTS: ADAPTER FITTING HOSE FITTING BRASS SLEEVE BRASS NUT HOSE WASHER	10244901	1
22	CLIP	B5720301	1
23	CLIP-SPEED	M0114003	1
24	TUBING CLAMP	M0102301	1
25	BRACKET-IM (ATTACHED TO ICE MAKER)	B8391801	1
26	3/8" LONG SHEET METAL SCREW (ATTACHED TO ICE MAKER)	M0211116	1
27	CLIP-THERMAL FUSE (ATTACHED ICE MAKER)	10319801	1
28	INSERT-JUICE RACK	C8986117	1
29	INSERT-JUICE RACK	C8986118	1
30	INSERT-JUICE RACK	C8986111	1
31	INSERT-JUICE RACK	C8986113	1
32	INSERT-JUICE RACK	C8986114	1
33	INSERT-PLASTIC TUBE	A3223101	1
34	HOLE PLUG-FRZ BACK RACK-JUICE	A3124301	2
35	RACK-JUICE	D7839703	1

Installation Materials Needed

Except for the parts furnished with the ice maker kit, the only material needed is a length of 1/4 inch copper tubing. This tubing must be long enough to reach from the water pipe location selected for the saddle valve, plus an additional six (6) feet to allow for servicing the refrigerator or freezer. This should be "soft" tubing, as opposed to "rigid" tubing, and the ends should be free of any cutting burrs.

NOTE: If the household water supply contains sand or sediment, or if it tastes objectionable, a disposable activated carbon water filter can be installed in the water line supplying the ice maker. The filter is not included with the ice maker kit. Consult your appliance dealer for availability.

Recommended Tools

To install the ice maker kit properly and conveniently, use the following basic tools.

- Center punch.
- Hammer.
- Electric drill (ground fault protected).
- 1/4 in. drill bit.
- 1/4 in. hex socket and driver.
- Adjustable wrench
- Two, 1/2 in. open end wrenches.
- Flat blade screw driver.
- Pliers.
- Small knife.
- Masking tape.
- 3/8 in. drill bit.

Safety Instructions

Read and understand the following safety instructions before proceeding with the installation.

⚠️ WARNING: To avoid the risk of electrical shock, which can cause severe personal injury or death, observe the following precautions:

1. Disconnect the refrigerator or freezer from its electrical power source.
2. Make absolutely certain that the electric drill being used is properly grounded and/or double insulated.
3. Do not drill into a water pipe until the water has been shut off and the pipe has drained through a faucet at some low point in the water system.
4. If a horizontal water pipe is chosen, drill only into the side or top of it. Drilling on the underside can allow trapped water to enter the drill and cause electrical shock.

⚠️ CAUTION: Failure to observe the following may result in damage to your appliance or to other property:

1. Use care to ensure that you drill through only one wall of the water pipe in preparation for saddle valve installation.
2. Check carefully for any water leaks following installation of the ice maker kit, and before returning the refrigerator or freezer to its normal location.
3. Always start tubing nuts by hand, to avoid cross threading. Finish tightening the nuts using an adjustable wrench or a 1/2 inch open end wrench.

Kit Installation Procedure

For best results, perform the installation procedure in the order given below. Doing so will minimize the time during which the household water supply is turned off, and the time during which the refrigerator or freezer must be disconnected.

Note that unless otherwise stated, all parts referenced throughout the installation procedure are from the ice maker kit.

1. Install water supply saddle valve and connect copper tubing:

- a. A suitable cold water pipe should have been selected prior to purchasing the 1/4 inch copper tubing that will carry ice making water to the refrigerator or freezer. If convenient, a vertical pipe is preferred.

- b. Shut off the household water supply at the main water valve.
- c. Open a cold water faucet, at some low point in the water system. Allow the cold water system to drain until water no longer flows from the faucet.
- d. Select the exact spot on the water pipe at which the hole is to be drilled, and mark the spot using a center punch and hammer.
- e. Drill a 1/4 inch hole through the top or one side wall of the selected pipe, as applicable. Use care to avoid drilling through the opposite wall of the pipe.

- f. Attach the saddle valve to the water pipe using the parts illustrated in Figure 1. Thread the valve to the saddle valve clamp. Make sure that the rubber washer is in place between the saddle valve clamp and the water pipe. Also note that the saddle valve clamp must be threaded onto the saddle valve stem before clamping the saddle valve to the water pipe. The valve will not thread completely into the saddle valve clamp because of tapered threads. Tighten

the two attaching screws evenly, in increments so the spacing is equal between both sides of the clamps.
Do not overtighten.

NOTE: Use only the saddle valve supplied with the ice maker kit, or an identical valve. Do not use a self-piercing type, as it may become restricted due to the small hole a piercing type valve makes in the water pipe.

- g. Slip the brass nut and brass sleeve onto the 1/4 inch copper tubing as shown in Figure 1.
- h. Insert the 1/4 inch copper tube into the saddle valve outlet port, making sure the tube is inserted fully. Be sure to start the nut by hand, turning clockwise, to avoid cross threading. Firmly connect the copper tubing to the saddle valve outlet fitting using a 1/2 inch open end wrench to secure the brass nut.
NOTE: Pull on the copper tubing to see if the tubing is secured to the coupling.

- i. Shut off the saddle valve, by turning the handle fully clockwise, and then turn on the household water supply valve.
- j. Make certain there are no leaks in the connections, and the saddle valve shuts off the water completely before proceeding.

2. Protect the floor when moving the refrigerator with sheet metal strips under the wheels. Unplug the refrigerator power cord from its electrical outlet, and then pull the refrigerator away from the wall. Position the refrigerator so its back is accessible.

- a. Route the copper tube up to the refrigerator, through the floor or the interior wall behind the refrigerator, whichever is more convenient using 3/8 in. holes when required.

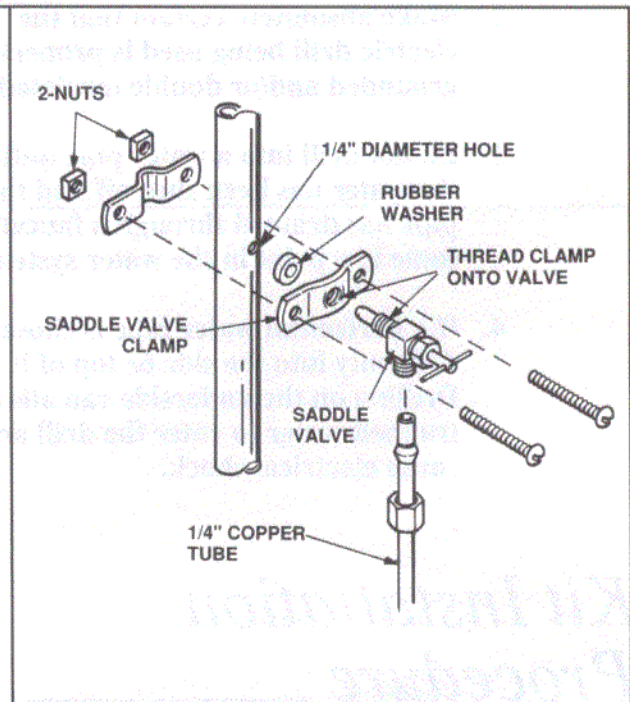

Figure 1

- b. Put the other end of the copper tube into a sink, or a pail if desired, and open the saddle valve slightly. Keep in mind that the water will be under considerable pressure. Allow the water to run through the copper tube for several minutes to flush out the saddle valve and the copper tube. Shut off the saddle valve when flushing is completed.

3. Remove the ice rack and freezer upper shelf.

- a. Remove ice cube trays from the ice rack.
- b. Slide the ice rack forward slightly to free it from the two holding screws (see Figure 2). Note that some effort may be required to do this.
- c. Remove the ice rack by moving it towards the center of the freezer compartment and then straight out the front of the compartment.

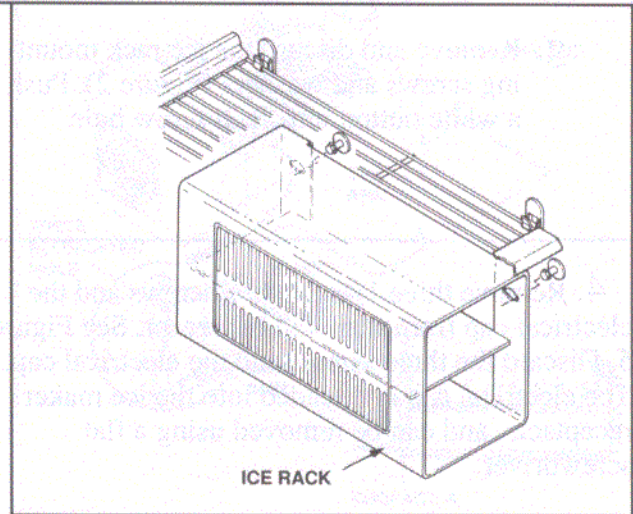

Figure 2

- d. Remove and discard the ice maker water cover from the back wall of the freezer. To do this, push upward against the tab inside of the cover using finger pressure; then tip the lower end of the cover toward you and disengage the upper tab. See Figure 3.

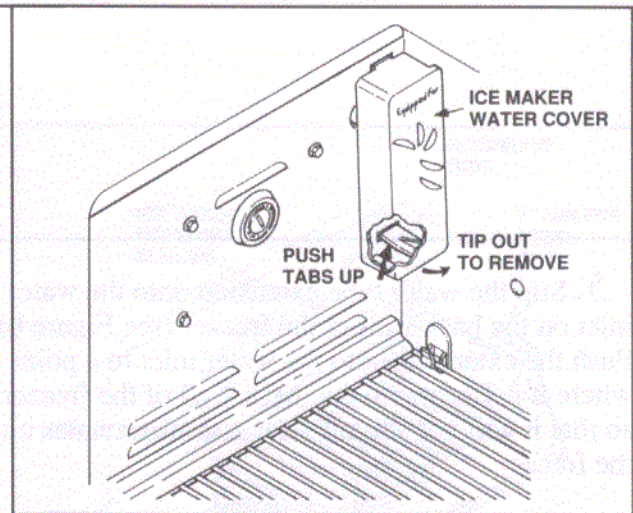

Figure 3

- e. The upper shelf can now be removed by first lifting it out of the hooks on your right, and then pulling the left side of the shelf from the pin holes in the left wall of the freezer. See Figure 4.
- f. Install the double prong plugs from the kit in the slotted holes that were used to mount the ice maker water cover on the back wall. See Figure 4.
- g. Remove and discard the ice rack mounting screws and washers (Figure 2). Push a white button into each screw hole.

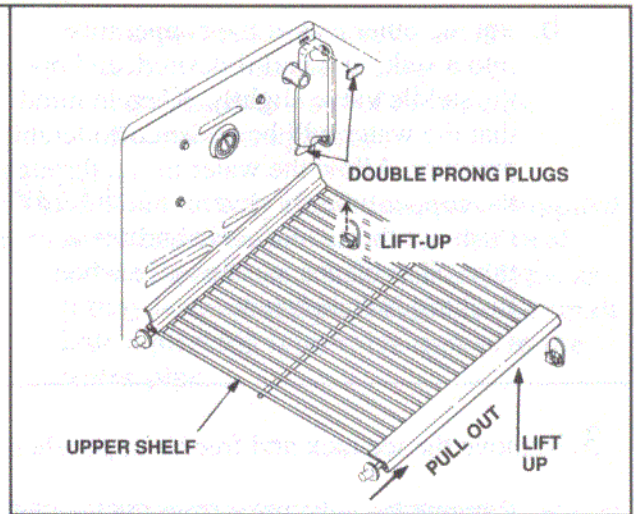

Figure 4

4. Remove three 1/4 inch hex screws and the electrical cap from rear wall of freezer. See Figure 5. Discard the three screws and the electrical cap. The electrical cap is threaded into the ice maker receptacle, and can be removed using a flat screwdriver.

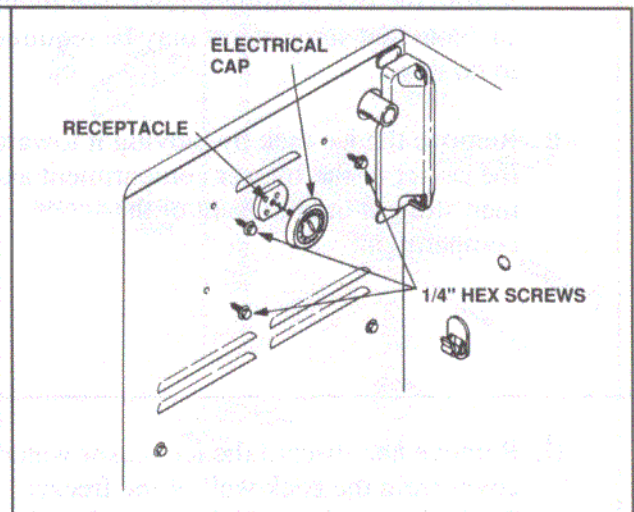

Figure 5

5. Slip the water tube extension onto the water inlet on the back wall of the freezer (see Figure 6). Push the extension onto the water inlet to a point where it is flush with the back wall of the freezer, so that it will not slip off later and allow water into the freezer.

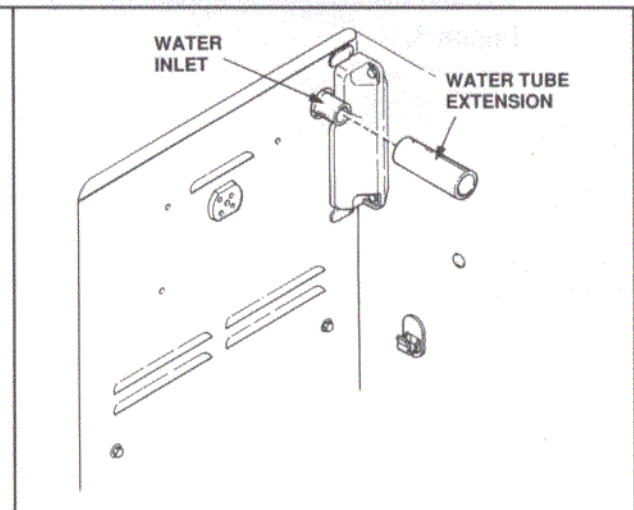

Figure 6

6. Assemble and install the ice maker:

- a. Remove the ice maker from the shipping carton and discard the packing material.
- b. Locate the wire shut-off arm. It is packed in a piece of cardboard for protection.

- c. Install the shut-off arm on the ice maker as shown in Figure 7. Install the straight end in the round hole in the water cup first; the flat end on the shut-off arm **MUST** go through the hole in the water cup. Then insert the other end in the white elongated hole in the ice maker housing. **Insert the end of the shut-off arm into the elongated hole only; not into one of the round holes in the ice maker housing (see Figure 7).** Make sure that the shut-off arm operates properly after installing. Move the shut-off arm up or down until you produce an audible click. Return the shut-off arm to the lowest position.

CRITICAL: Must push the shut-off arm completely in place, even with the ice maker surface. See Surface A.

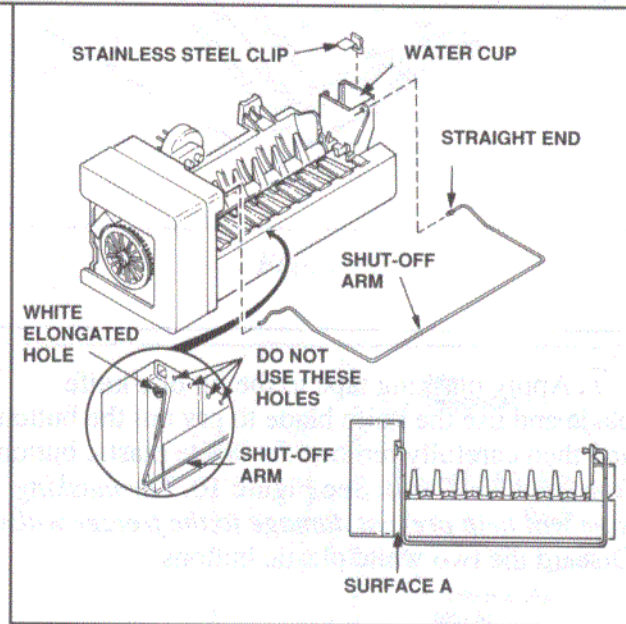

Figure 7

- d. Slip the stainless steel clip over the outside wall of the water cup. See Figure 7.

- e. Loosen the top two screws (silver colored) and remove the bottom screw. Save this screw for future use. Leave the heads sticking out far enough to allow the ice maker hangers to slip over the heads, approximately 3/8 in. See Figure 8.
- f. Hold the ice maker in position in the freezer and plug it into the electrical receptacle on the freezer back wall. Note the spacing of the four pins on the plug; the pins must line up exactly with the holes in the receptacle. See Figure 8.

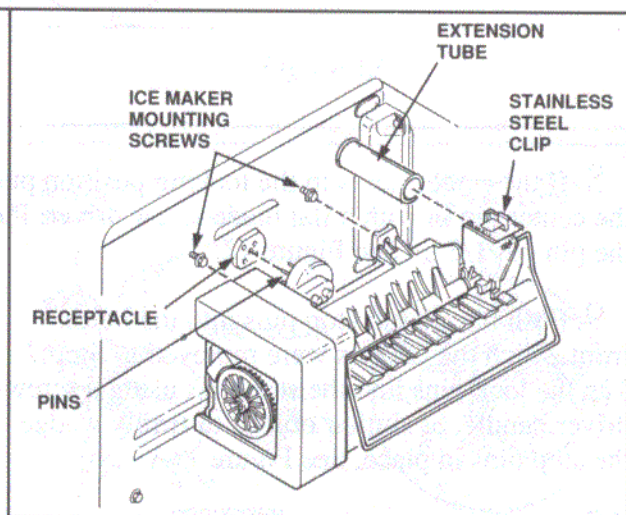

Figure 8

- g. Slip the ice maker hangers over the two mounting screws, while working the water tube extension under the stainless steel clip on the water cup. See Figure 8. **Make sure that the extension tube is not kinked and does not become dislodged from the water tube. For best results, the tube extension should extend approximately 1/2 inch into the water cup.**

- h. Install the third ice maker mounting screw (silver colored), and tighten all three. This completes installation of the ice maker. See Figure 9.

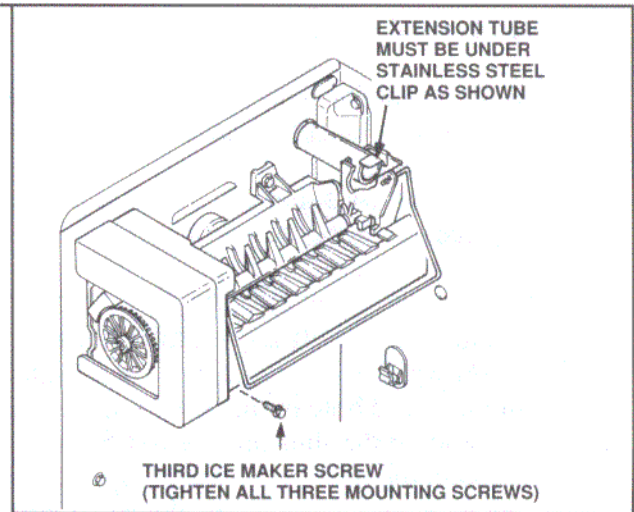

Figure 9

7. Apply masking tape to the tip of a knife blade and use the knife blade to pry out the buttons and then carefully remove the white plastic buttons from each side wall. See Figure 10. *The masking tape will help prevent damage to the freezer walls.* Discard the two white plastic buttons.

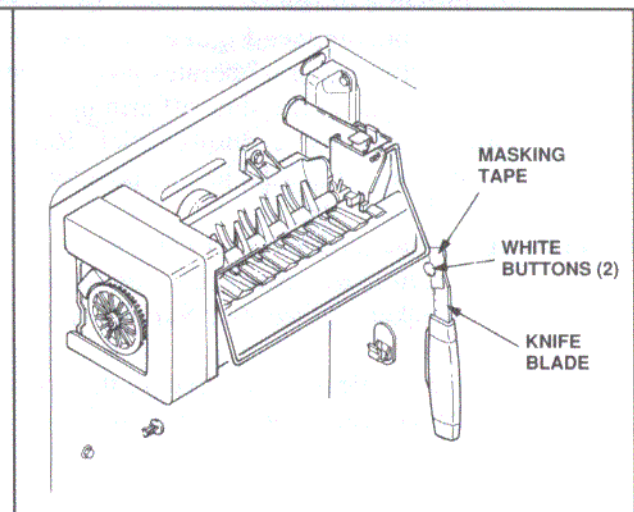
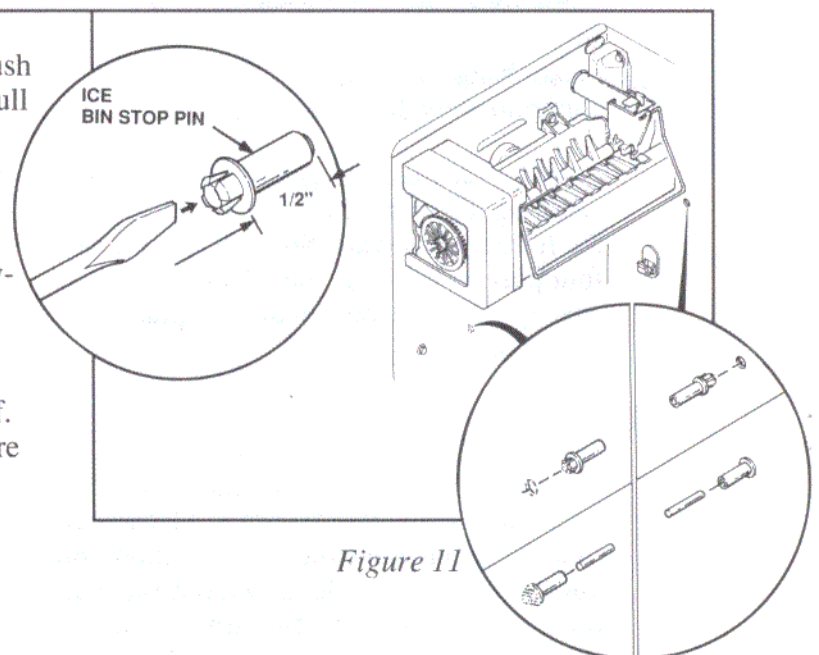

Figure 10

8. If the center pin is in the locking position push the center pin in with a flat blade screw driver. Pull the pin out 1/2 in. See Figure 11.

9. Push the ice bin stop pins into the holes from which the buttons were removed in Step 7. Tap the lock pins into the stop pins using a screwdriver handle, or similar object, to firmly wedge the stop pins in place. See Figure 11A.

10. Slide the ice bin onto the freezer upper shelf. Position the ice bin against the stop pins, to ensure proper placement of the bin.



11. Select the decorator insert that best matches the interior of your refrigerator or freezer. Remove the protective paper from the adhesive back of the insert and stick the insert onto the front face of the storage tray, starting at one end of the insert and carefully working to the other end. See Figure 12.

12. Reinstall the freezer upper shelf.

13. Place the storage tray on the ice bin and close the freezer door.

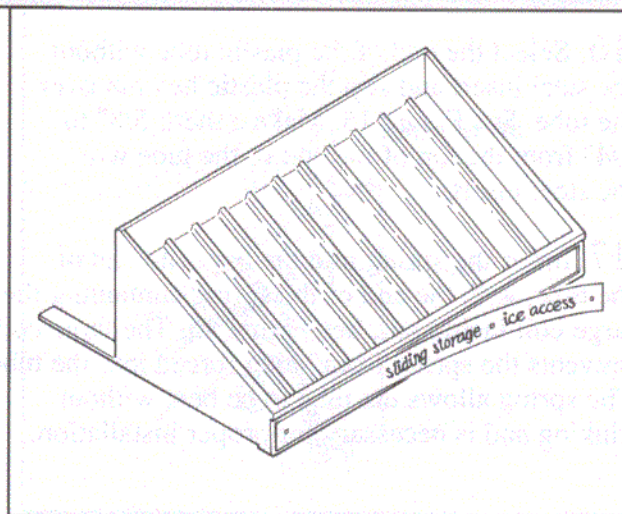

Figure 12

14. Remove the cover from the lower rear of the refrigerator and remove the upper sheet metal plate that covers the wire trough. See Figure 13. *Do not discard either the lower cover or the sheet metal plate.*

NOTE: It is important the cover be in place and all mounting screws are used when reinstalling.

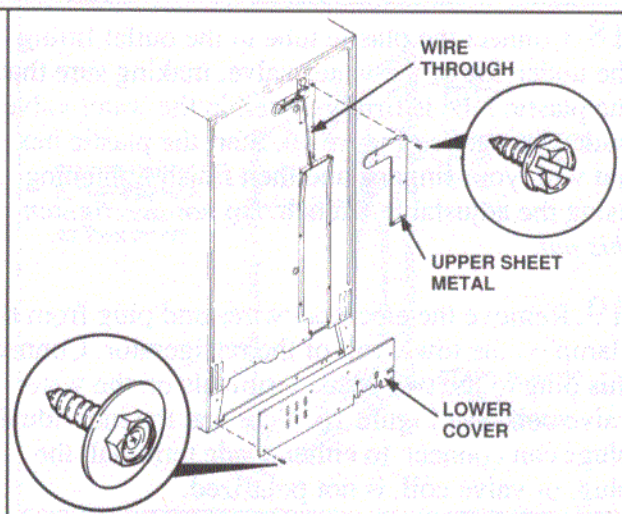

Figure 13

15. Assemble the bracket to the water valve and lock the bracket into place with the valve clip. See the inset. Note that the bracket fits behind the square collar on the water valve inlet and that the valve clip fits into the groove behind the threads on the water valve inlet. Attach the ground wire to one hole in the bracket using one brass colored, 1/2 inch long self-threading screw from the kit. See Figure 14.

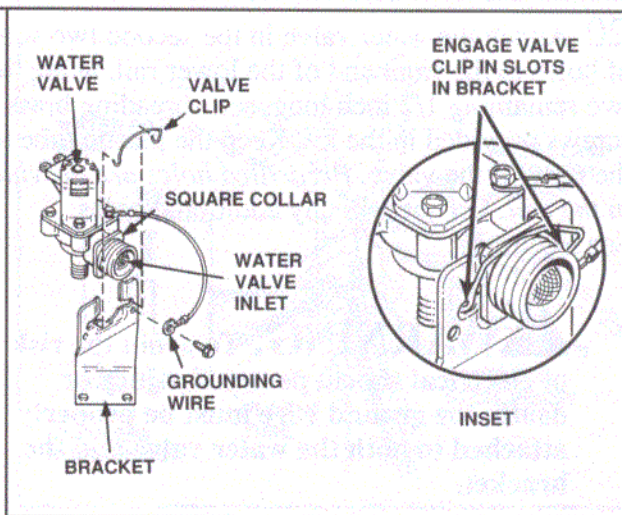

Figure 14

16. Select the end of the plastic tube without the steel insert and slip the plastic hex nut over the tube. See Figure 15. Make a mark 5/8" to 3/4" from the top of the end of the tube with the steel insert.

17. Insert the spring into the opposite end of the tube, with the end of the spring containing the large coil facing out. See Figure 15. The large coil prevents the spring from being forced into the tube. The spring allows the tube to be bent without kinking and is necessary for proper installation.

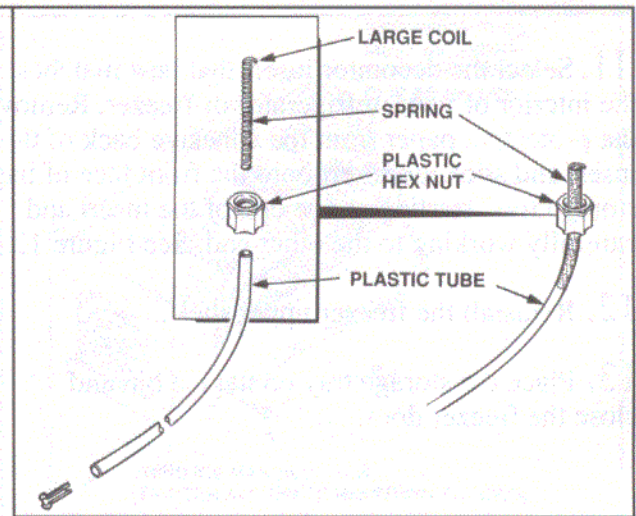

Figure 15

18. Connect the plastic tube to the outlet fitting on the underside of the water valve, making sure that the plastic tube is firmly seated in the water valve outlet fitting. See Figure 16. Start the plastic hex nut with your fingers, and then finish tightening using the adjustable wrench. *Do not overtighten this nut.*

19. Remove the electrical wires and plug from the clamp on the lower rail of the refrigerator. Connect this plug to the two spade terminals on the water valve coil. See Figure 16. Note that the individual plugs can connect to either spade terminal; the plug, or valve coil, is not polarized.

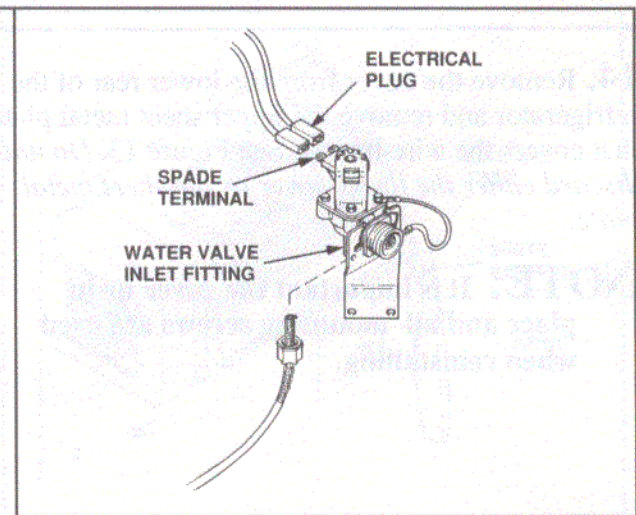

Figure 16

20. Attach the water valve in the second two sets of holes to the front end of the lower rail, using the two remaining 1/2 inch long, self-threading brass screws provided in the kit. Keep the plastic tube to the right of the valve. *Pre-drilled holes are provided in the rail.* Do not drill any additional holes. See Figure 17.

⚠ WARNING: To avoid the risk of electrical shock, personal injury or death, the ground wire must be properly attached to both the water valve and the bracket.

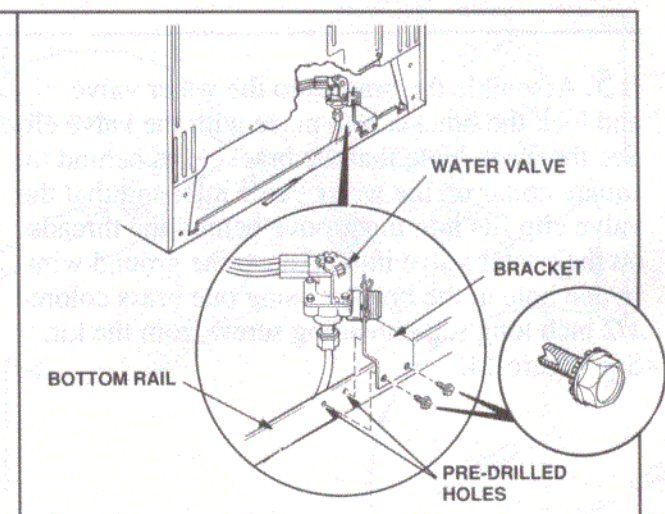

Figure 17

21. Remove the cap from the water fitting on the back of the refrigerator. See Figure 18.

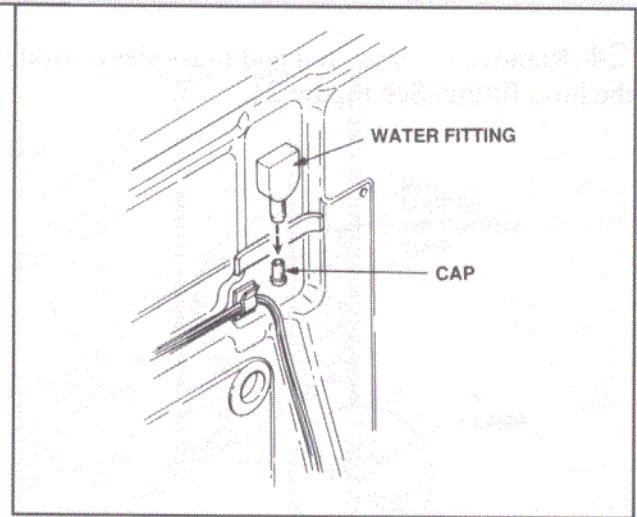

Figure 18

22. Work the plastic tube up under the sheet metal cover on the back of the refrigerator or freezer, then in behind the wire harness and up to the water fitting. See Figure 19. Note that the tube must be inserted into the bottom of the sheet metal cover at the lower right corner, as you face it.

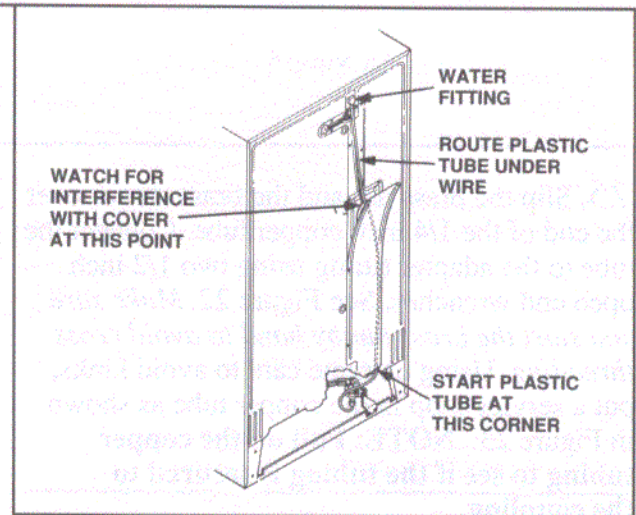

Figure 19

23. Slip the tube clamp over the stem of the water fitting (see Figure 20) and hold the clamp open using a pliers. Slip the tube end into the water fitting stem a distance of 5/8 to 3/4 inch and release the tube clamp. Check to make sure that the tube is held firmly in the water fitting stem by the clamp.

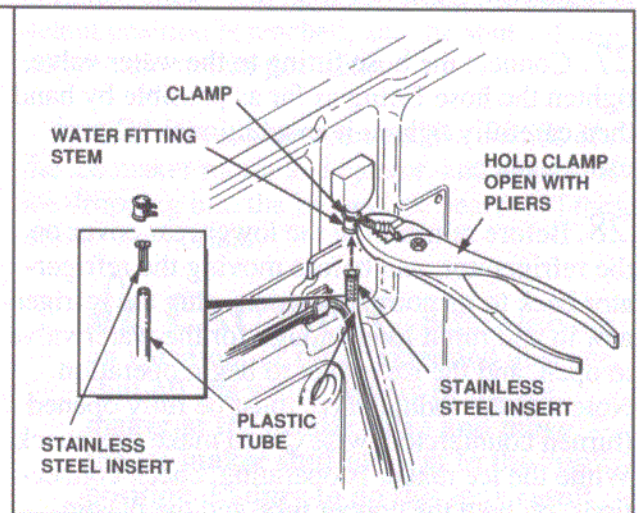

Figure 20

24. Remove the brass nut and brass sleeve from the hose fitting. See Figure 21.

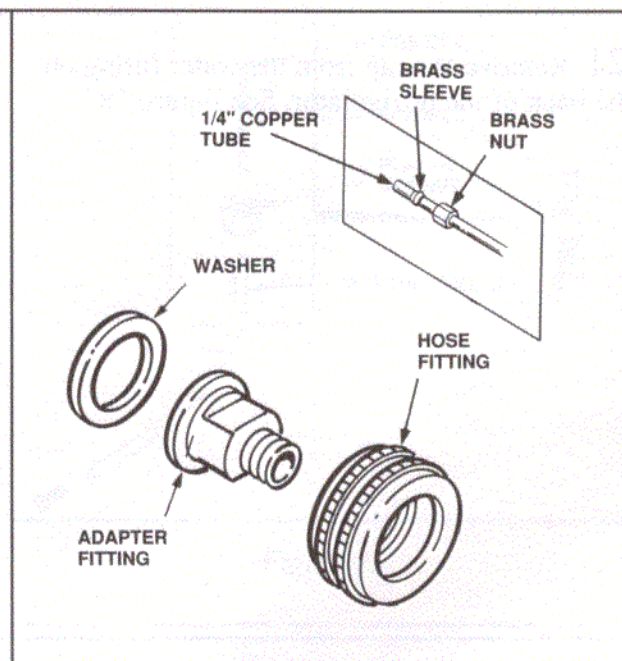

Figure 21

25. Slip the brass nut and the brass sleeve over the end of the 1/4 inch copper tube. Connect the tube to the adapter fitting using two 1/2 inch open end wrenches. See Figure 22. *Make sure you start the brass nut by hand to avoid cross threading.* Using extreme care to avoid kinks, put a service loop in the copper tube as shown in Figure 23. **NOTE: Pull on the copper tubing to see if the tubing is secured to the coupling.**

26. Check the hose fitting to assure the washer is in place.

27. Connect the hose fitting to the water valve, tighten the hose fitting as far as possible by hand, then carefully tighten it an additional 1/2 turn using a pliers.

28. Before reinstalling the lower rear cover on the refrigerator, and before moving the refrigerator back to its normal position, plug the refrigerator in and run it long enough for the water valve to open, and the ice maker to begin operation. Note that the saddle valve must be fully opened (turned counterclockwise \odot) to make this check. While the ice maker is operating, check connections on both the copper tube and the plastic tube for leaks. Also check to be sure the water extension tube in the freezer compartment remains firmly in place on the water tube and that water is entering the water cup properly.

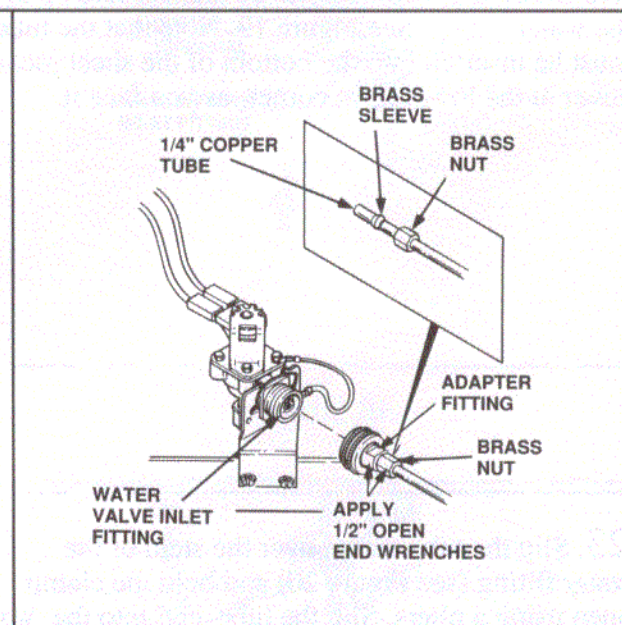

Figure 22

29. When you are confident that no leaks exist or after correcting any apparent leaks, install the lower rear cover on the refrigerator. Clamp the copper tube to the back of the unit using the "P" clamp provided in the kit and the upper right attaching screw of the lower rear cover. Using extreme care to avoid kinks, put a service loop in the copper tube as shown in Figure 23.

30. Install the upper sheet metal cover on the back of the refrigerator. See Figure 13.

⚠ CAUTION: Make sure that the plastic tube and the electrical wires do not become pinched under the sheet metal cover.

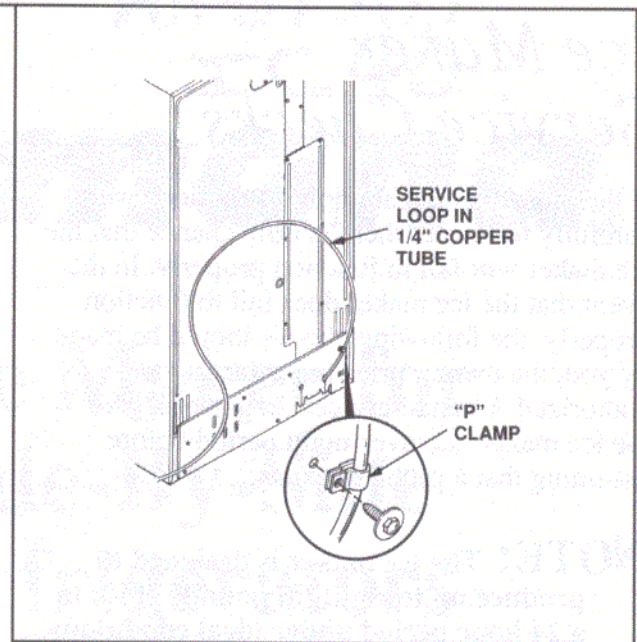

Figure 23

31. Move the refrigerator back to its normal position and turn the freezer control to the mid position.

Operation of Ice Maker

1. Check to be sure that the ice bin is in place, that the ice maker shut-off arm is in the "down" position and that the saddle valve is open (turned counterclockwise).

2. After the freezer reaches normal temperature ice cubes will be produced.

3. Ice will now be lifted out of the ice maker after it is formed, and be deposited in the ice bin. This will continue until the ice bin is filled, at which time the ice maker will automatically shut off.

NOTE: The first three harvests of ice should be discarded, since they may contain contaminants from the ice maker or from the water system.

4. To stop the ice maker at any time, lift the shut-off arm to the upper detent position. A definite "click" will be heard when the upper detent position is reached, and the shut-off arm will remain in that position.

5. As the ice maker operates, the sounds of the ice maker motor and ejector, and sounds of ice dropping into the bin will be heard. All these sounds are normal.

⚠ CAUTION: Before leaving on vacation, or other extended absence, shut off the water supply to the ice maker at the saddle valve and move the ice maker shut-off arm to the "up" position. Failure to do this may result in possible property damage.

Ice Maker Service Checks

If the preceding installation instructions were carefully followed, there is little chance that the ice maker will fail to function properly. In the event that the ice maker does fail to function properly, the following checks should be made by you, the owner, prior to contacting an authorized Amana Servicer. In general, give the ice maker one over-night period before assuming that a problem exists.

NOTE: The ice maker is designed to produce up to eight (8) pounds of ice in a 24 hour period under ideal conditions of room temperature, water inlet temperature and freezer compartment interior temperature. If low ice production is experienced, the preceding conditions should be considered before assuming a problem with the ice maker itself. A freezer compartment interior temperature above +2° F will noticeably affect ice production, as will room temperatures above 75° F.

⚠ WARNING: To avoid the risk of electrical shock, which can cause severe personal injury or death, disconnect the refrigerator from its power source before attempting any disassembly.

1. Check to make sure that the saddle valve installed on the house water pipe is fully turned on (handle fully counterclockwise).

2. Make sure that the ice maker wiring harness plug pins are fully inserted into their proper holes in the receptacle at the rear of the freezer compartment.

3. Check closely for kinks in either the copper tube or in the plastic tube, which could block the flow of water to the ice maker. Remove the kinks or replace the kinked tube, as appropriate.

4. Remove the lower rear cover from the refrigerator (Figure 13) and check the electrical connections to the water valve coil. The plugs must be tight on the spade terminals of the water valve coil. *Replace the lower rear cover before returning the refrigerator to normal use. The refrigerator will not operate properly with this cover removed.*

CONSUMER INFORMATION LINE



AMANA TOLL FREE

1-800-843-0304